

Protection conferred by recombinant *Yersinia pestis* antigens produced by a rapid and highly scalable plant expression system

Luca Santi^{*†}, Anatoli Giritch^{*†}, Chad J. Roy[§], Sylvestre Marillonnet[‡], Victor Klimyuk[‡], Yuri Gleba[‡], Robert Webb[§], Charles J. Arntzen^{*¶}, and Hugh S. Mason^{*¶}

^{*}Biodesign Institute, Arizona State University, Tempe, AZ 85287-5401; [†]Icon Genetics, Biozentrum Halle, Weinbergweg 22, D-06120 Halle (Saale), Germany; and [§]U.S. Army Medical Research Institute of Infectious Disease, Fort Detrick, MD 21702

Contributed by Charles J. Arntzen, November 27, 2005

Plague is still an endemic disease in different regions of the world. Increasing reports of incidence, the discovery of antibiotic resistance strains, and concern about a potential use of the causative bacteria *Yersinia pestis* as an agent of biological warfare have highlighted the need for a safe, efficacious, and rapidly producible vaccine. The use of F1 and V antigens and the derived protein fusion F1-V has shown great potential as a protective vaccine in animal studies. Plants have been extensively studied for the production of pharmaceutical proteins as an inexpensive and scalable alternative to common expression systems. In the current study the recombinant plague antigens F1, V, and fusion protein F1-V were produced by transient expression in *Nicotiana benthamiana* by using a deconstructed tobacco mosaic virus-based system that allowed very rapid and extremely high levels of expression. All of the plant-derived purified antigens, administered s.c. to guinea pigs, generated systemic immune responses and provided protection against an aerosol challenge of virulent *Y. pestis*.

plague | viral vector | plant biotechnology | recombinant subunit vaccine

The Gram-negative bacterium *Yersinia pestis* is the causative agent of plague, severely affecting human health since ancient times, and is still endemic in Africa, Asia, and the Americas (1). The bubonic form of the disease is transmitted to humans via the bite of an infected flea, and from the local sites of infection the bacteria can disseminate systemically. The pneumonic form of the disease, considered uniformly fatal, can develop either from a fulminant bubonic state or can be directly induced from an intentional aerosol attack. Pneumonic plague is also communicable via aerosol from infected to naïve host, making *Y. pestis* a transmissible bioterrorism agent (2).

The two human vaccines formulated as a suspension of killed whole cells (KWC) are the formaldehyde-killed Cutter vaccine, no longer in production, and the Commonwealth Serum Laboratories vaccine, a heat-killed preparation of *Y. pestis*. These KWC vaccine formulations provide very little protection against the pneumonic form of the disease, have a high incidence of side effects, and require an intensive schedule of priming and boosting to achieve protective immunity (3, 4).

A live attenuated vaccine (EV76) has been used in humans; however, in this case transient local and systemic side effects were also reported and the vaccine has never been approved for use in the United States (5). Thus, there is a great need for improved plague vaccines.

The use of recombinant subunit vaccines based on the fraction 1 capsular antigen (F1), the V antigen, and F1-V fusion protein has proven to be a successful strategy in several animal and human clinical studies. F1 is encoded on a 110-kb plasmid (pMT-1); it is highly expressed and exported to form an extracellular capsule conferring antiphagocytic properties to *Y. pestis* cells. Sera from patients show high levels of anti-F1 antibody, and F1 stimulates protective immunity in mice that are paren-

terally challenged with the virulent bacteria (5, 6). F1 elicits strong antibody responses in humans vaccinated with purified native antigen (5).

Another subunit vaccine candidate, the *Y. pestis* V antigen, is a secreted protein encoded on the 70-kb plasmid pCD1. Besides participating in controlling the low calcium response, the V protein is an immunomodulator that can suppress the host innate immune response (7–9). Recombinant V antigen produced in *Escherichia coli* elicits complete protection against challenge in mice (10). Furthermore, passive immunization with sera raised against the purified V antigen can protect against s.c. challenge (11). A combined formulation in an optimum molar ratio of F1 and V showed levels of protection in mice at least three orders of magnitude greater than that provided by the killed whole cells vaccine (3). A genetic fusion of the two antigens (F1-V) also provoked high titer and long-lasting protective antibodies in animals (12, 13).

In recent years, there has been considerable interest in the use of transgenic plants to generate compounds for medical and veterinary use. A variety of molecules have been successfully expressed in plants, including peptides (14), human proteins and enzymes (15), viral and bacterial antigens (16, 17), and many different forms of antibodies (18–21). A major limitation with the use of stable transgenic plants for production of pharmaceutical proteins has been the relatively low level of expression, usually <1% total soluble protein (TSP). Transient expression using plant viral vectors can yield much higher expression. For example, the magnICON system (Icon Genetics) allowed expression of GFP in leaves of *Nicotiana benthamiana* at up to 5 mg per g of leaf mass and 80% TSP (22–24). This deconstructed tobacco mosaic virus (TMV)-based system couples extremely high levels of expression with speed in production and scalability.

In this article we describe the use of unique vectors (22–24) for robust expression of recombinant *Y. pestis* F1, V, and F1-V fusion proteins in leaves of *N. benthamiana*, purification of antigens, and immunization of guinea pigs to provide protection against aerosol challenge. This report demonstrates a rapid, efficient expression system in plants to produce antigens from agents of biological warfare.

Conflict of interest statement: A.G., S.M., V.K., and Y.G. are employees/founders of Icon Genetics.

Freely available online through the PNAS open access option.

Abbreviations: TMV, tobacco mosaic virus; dsRED, *Discosoma* sp. red fluorescent protein; DM/PBS, dry milk in PBS; NTA, nitrilotriacetic acid.

Data deposition: The sequence reported in this paper has been deposited in the GenBank database (accession no. DQ229852).

[†]L.S. and A.G. contributed equally to this work.

[¶]To whom correspondence may be addressed. E-mail: charles.arntzen@asu.edu or hugh.mason@asu.edu.

© 2006 by The National Academy of Sciences of the USA

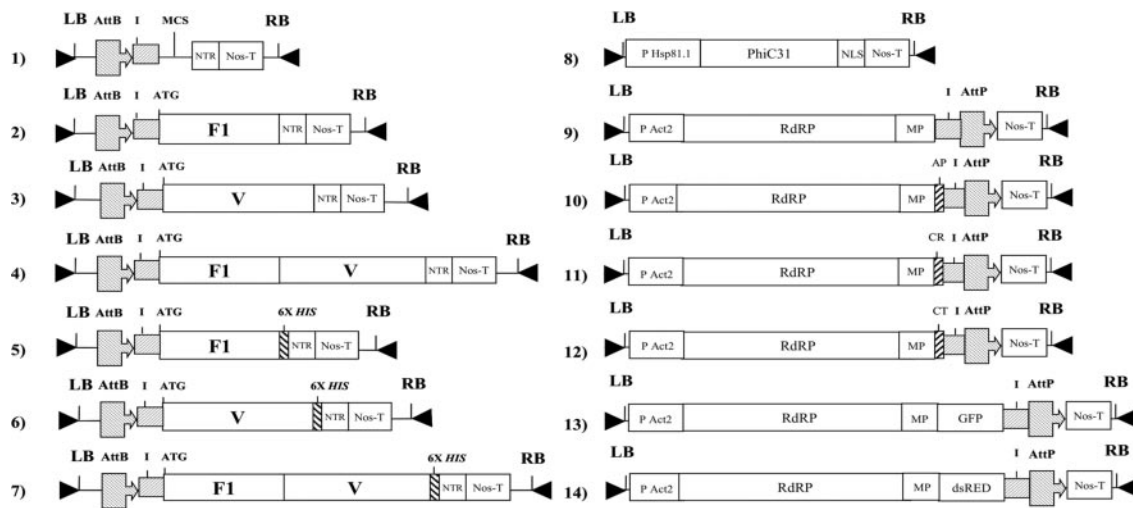

Fig. 1. Constructs used in the studies. 1–7, 5' pro-vector modules: 1, pICH11599; 2, pICH18320; 3, pICH18570; 4, pICH18330; 5, pICH18350; 6, pICH18560, and 7, pICH18360. 8, integrase module, pICH14011. 9–14, 3' pro-vector modules: 9, pICH15879; 10, pICH10530; 11, pICH8420; 12, pICH18750; 13, pICH18132; and 14, pICH18141. LB and RB, binary vector left border and right border, respectively; I, intron; MCS, multiple cloning site; AttB and AttP, DNA-specific recombination elements; NTR, nontranslated region; T, terminator; P, promoter; AP, apple pectinase apoplast targeting signal; CR, tobacco calreticulin apoplast targeting signal; CT, synthetic chloroplast targeting sequence; PhiC31, integrase; 6× HIS, histidine tag; MP, movement protein.

Results

Gene Engineering, Plasmid Construction, and Sequence Optimization.

A fully optimized plant gene sequence for F1-V was designed based on the previously described fusion gene (12). The sequence was engineered with specific restriction sites to allow the F1 and V gene sequences to be cloned separately or as a gene fusion. Of the native *Y. pestis* sequence codons 21.5% were changed to *N. benthamiana*-preferred codons. Possibly deleterious sequence motifs removed included four CNG and one CCGG potential methylation sites, four putative 5' intron splicing sites, 56 putative plant polyadenylation signals, and four potential mRNA destabilizing sequences. Overall the optimization procedure modified the AT percentage from 60% in the native gene to 58% in the plant optimized. No alterations in amino acids composition were introduced. The F1 portion consists of 150 amino acids followed by two linker amino acids, Glu and Phe, and the 326 amino acids of the entire sequence of the V antigen. Therefore F1-V consists of 478 amino acids with a predicted molecular mass of 53,300 Da, whereas F1 and V are predicted to weigh 15,694 and 37,238 Da, respectively.

magnICON System-Mediated Expression in *N. benthamiana*. A plant-based transient expression system was used to rapidly achieve high levels of protein production. The system relies on a deconstructed TMV replicon strategy. Different *Agrobacterium* cell lines, harboring different modules of the viral vector and the gene of interest, are used to transiently deliver the DNA constructs to the plant nucleus where they assemble into full TMV-based viral replicons when coexpressed with a specific recombinase (22, 23). This approach allowed easy testing of different targeting presignals or fusions with GFP or *Discosoma* sp. red fluorescent protein (dsRED) by combining the single 3' modules, each one containing, respectively, the plant-optimized coding sequence for F1, V, or F1-V fusion with the appropriate 5' modules. The schematic representation of all 3' and 5' modules and the construct carrying the integrase of the phage Phi C31 is shown in Fig. 1. Two constructs, pICH18320 and pICH18330, carrying F1 antigen and F1-V antigens, respectively, were tested in combination with the different 5' provector modules in leaves of *N. benthamiana* grown under standard greenhouse conditions. At 10 days postinfection, which is re-

ported to be the preferred harvesting time for this expression system (23), no apparent sign of toxicity, because of the massive heterologous protein accumulation, was detected. Harvested samples were analyzed by SDS/PAGE with Coomassie staining. F1 was highly expressed in cytosol at levels estimated at $\approx 2 \text{ mg}\cdot\text{g}^{-1}$ of fresh leaf weight. Testing the expression of F1 translational fusions with different targeting presequences showed that it was highly also expressed when targeted to the apoplast. The level of F1 targeted to chloroplasts was lower, but still detectable on a Coomassie-stained gel (Fig. 2A). We con-

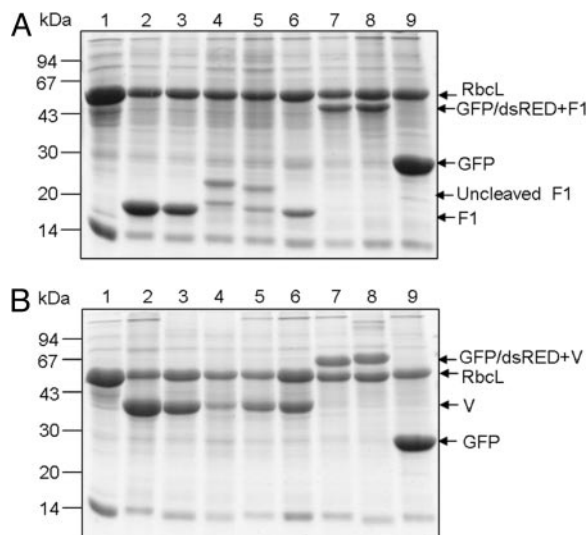

Fig. 2. Coomassie-stained gels (SDS/PAGE) containing total soluble proteins from *N. benthamiana* leaves harvested at 7 days postinfection inoculated with different combinations of 5' targeting and 3' provector modules for expression of F1 (A) and V (B) antigens with C-terminal His(6) tag. Uninfected leaf (lanes 1), cytosol-targeted antigens (lanes 2 and 3), fusion with calreticulin signal sequence for apoplasmic targeting (lanes 4), fusion with pectinase signal sequence for apoplasmic targeting (lanes 5), chloroplast-targeted antigens (lanes 6), cytosolic-targeted translational fusions with GFP (lanes 7), cytosolic-targeted translational fusions with dsRED (lanes 8), and cytosol-targeted GFP (lanes 9). RbcL, large subunit of Rubisco.

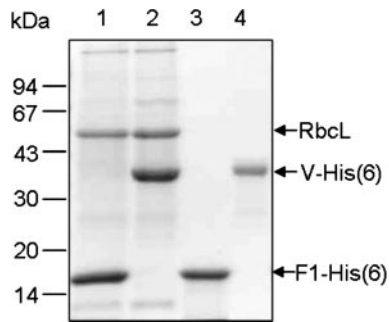

Fig. 3. Coomassie-stained gels (SDS/PAGE) showing Ni-NTA agarose purification of F1 and V antigens with C-terminal His(6) tag cytosolic expressed in *N. benthamiana* leaves. Lane 1, F1-His(6) expression, crude protein extract; lane 2, V-His(6) expression, crude protein extract; lane 3, Ni-NTA agarose-purified and -desalted F1-His(6); and lane 4, Ni-NTA agarose-purified and -desalted V-His(6). RbcL, large subunit of Rubisco.

clude that cytosolic targeting is preferred for F1 antigen.

The analysis of F1-V expression with SDS/PAGE-Coomassie staining was difficult because the chimeric protein comigrates with the large subunit of Rubisco, a very abundant leaf protein. However, comparing the intensities of corresponding protein bands in different lanes, we concluded that F1-V was expressed at a relatively high level. Moreover, model translational fusion proteins, GFP-F1-V and dsRED-F1-V, used for system optimization, showed strong bands on a Coomassie-stained gel. To reliably quantify the level of expression, leaf extracts were analyzed by using direct ELISA. F1-V targeted to the cytosol accumulated at levels of $1 \text{ mg} \cdot \text{g}^{-1}$ of fresh leaf weight.

Experiments shown in Fig. 2 used denaturing SDS sample buffer for extraction. For the preparative isolation of F1 and F1-V proteins in active form, nondenaturing extraction was necessary; a phosphate buffer (pH 7.0) without detergents was tested for this purpose. We found that this buffer was efficient for the preparative isolation of both proteins in undegraded form (data not shown).

The expression of *Y. pestis* V antigen was evaluated by using construct pICH18570 coupled with different targeting elements as for F1 and F1-V above. SDS/PAGE with Coomassie staining showed the highest expression for cytosolic targeting again at levels of $\approx 2 \text{ mg} \cdot \text{g}^{-1}$ of fresh leaf weight. Expression of V antigen with apoplast or chloroplast targeting was lower, but still significant (Fig. 2B). Also in this case, no detrimental effects caused by the overexpression of the bacterial antigen could be detected. We conclude that cytosolic targeting was optimal for the V antigen.

Purification of *Y. pestis* Antigens. Different purification strategies were tested. For metal affinity chromatography, corresponding 3' provector constructs with C-terminal $6 \times$ His tags were tested. Alternatively, ion exchange chromatography was used on non-tagged proteins.

Purification of His-tagged protein. F1 antigen with C-terminal His(6)tag-expressed in cytosol was purified by using Ni-nitrilotriacetic acid (NTA) agarose (Qiagen, Valencia, CA). Purification was done in batches under native conditions. Eluted proteins were collected and analyzed by SDS/PAGE (Fig. 3; the elution profile of Ni-NTA agarose purification is provided in Fig. 7, which is published as supporting information on the PNAS web site). Samples were desalted, concentrated, and lyophilized. Twelve milligrams of final lyophilized product was obtained from 10 g of fresh leaf material.

Purification of V antigen. His-tagged V antigen was purified as described for F1 antigen and analyzed by SDS/PAGE (Fig. 3). Two batches (27 and 9 mg) of lyophilized material were obtained.

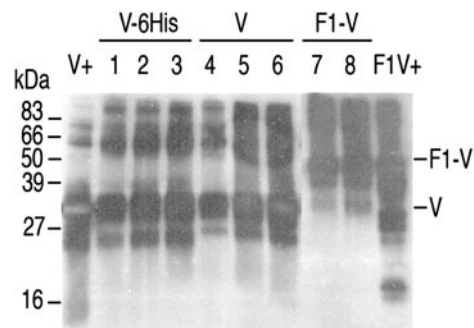

Fig. 4. Western blot probed with anti-F1-V serum. Purified antigens from *N. benthamiana* leaf were resolved by SDS/PAGE, blotted, and probed with rabbit anti-F1-V serum. Lane V+, *E. coli* recombinant V antigen, 40 ng. Lanes 1–3, plant-produced V-6His, 50, 150, and 200 ng, respectively. Lanes 4–6, plant-produced V antigen, 50, 150, and 200 ng, respectively. Lanes 7 and 8, plant-produced F1-V, 150 and 200 ng, respectively. Lane F1V+, *E. coli* recombinant F1-V, 40 ng.

Purification of F1-V antigen. F1-V with either C-terminal or N-terminal His tag was not expressed properly (data not shown). Anion-exchange chromatography on Q Sepharose Fast Flow was performed for the purification of untagged protein. Bis-Tris buffer (20 mM, pH 6.5) was used for the extraction of protein and the washing of column. The same buffer with gradient of NaCl concentration was used for the elution of protein. Fractions with partially purified protein were desalted by ultrafiltration and lyophilized. Approximately 10 mg of final lyophilized product was obtained. This product is likely partially contaminated by the Rubisco large subunit, which is very similar in size to F1-V.

Analysis of Purified Plant-Produced Antigens. Western blots were performed on V, V-6His, and F1-V antigens probed with rabbit antiserum against F1-V fusion produced in recombinant *E. coli*. Plant-produced V and V-6His showed mobilities similar to the *E. coli* recombinant V antigen (Fig. 4). Interestingly, they also showed higher M_r forms, perhaps oligomers, which comigrated with similar bands in the *E. coli* recombinant V antigen. Plant-produced F1-V also showed a main band that comigrated with the *E. coli* recombinant F1-V at the expected size (≈ 53 kDa). There was little indication of degradation products running at faster mobility in the plant samples, unlike the *E. coli* recombinant F1-V, which showed substantial amounts of lower M_r products. Also the plant-produced purified F1-6His showed reactivity in Western blot analysis when probed with rabbit antiserum against F1 (data not shown).

ELISAs for antigens F1, V, and F1-V fusion were performed by using the *E. coli* recombinant antigens as reference standards and specific polyclonal antisera against these antigens. Plant-produced antigens (purified as described above) were diluted according to estimations of protein content based on visual evaluation of Coomassie-stained gels. The OD values from ELISA were plotted to determine a more accurate antigen level by comparison with the standard curves produced from the bacterial antigens. These studies showed that the Coomassie gel method had overestimated the purified antigen content up to 3-fold. The corrected values were used to determine dosages in the animal immunization study below.

Immunogenicity and Challenge. We used plant-derived antigens to vaccinate groups of guinea pigs at days 0 (prime), 30 (boost 1), and 60 (boost 2). Serum antibody titers specific for antigens F1 and V are shown in Fig. 5. Anti-F1 titers in F1-V and F1-His antigen groups showed significant increases over the sham-immunized animals after boost 1 and further increased after boost 2. Titers after boost 2 were 17,222 and 20,480, respectively,

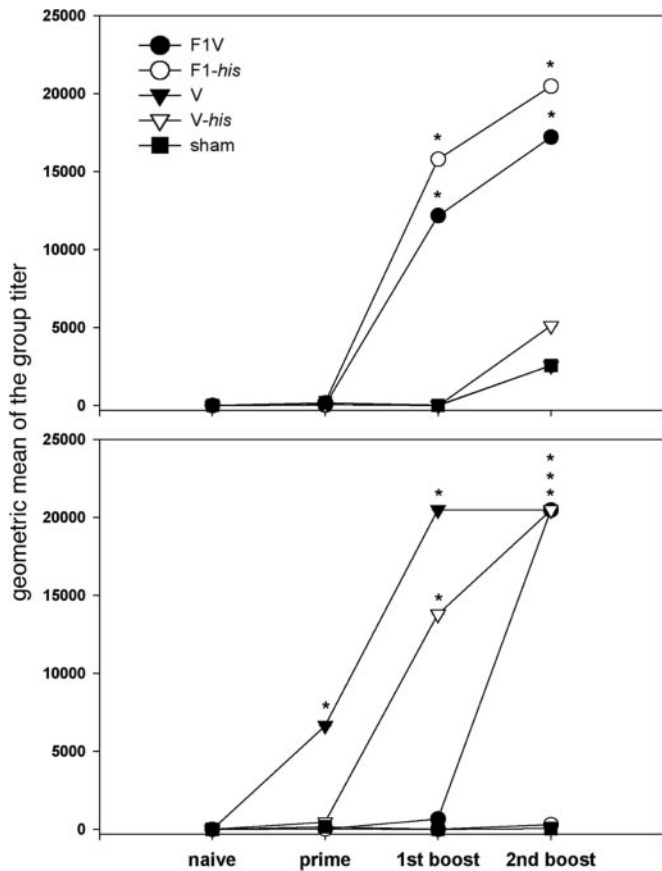

Fig. 5. Serum antibody response to vaccination of guinea pigs. Group means with standard error are shown. IgG titers specific for F1 (Upper) or V (Lower) are shown. The asterisk (*) denotes significance at <0.001 when compared against sham-vaccinated controls.

for F1-His and F1-V. Anti-V titer increased significantly after the priming dose only for V; titers for V, V-His, and F1-V all climbed to 20,480 after boost 2. Thus, the F1-V fusion was highly immunogenic for both F1 and V.

Four weeks after the second boost, animals were challenged by aerosol to *Y. pestis* (CO92). The resulting challenge dose was determined at 61 ± 15 LD₅₀. The survival curves for each group are shown in Fig. 6. Whereas all of the sham-vaccinated animals were dead within 6 days after exposure, all of the antigen-vaccinated groups showed significant rates of survival at 21 days postexposure. V-vaccinated animals showed the highest survival rate (six of eight), followed by F1-V and V-His (five of eight) and F1-His (three of eight). Moreover, of the antigen-vaccinated animals that died from exposure, most deaths were delayed significantly beyond 6 days, the last being at 14 days for the F1-His group.

Discussion

Plague is one of the oldest identifiable and historically most deadly diseases to humans. *Y. pestis* is found in natural reservoirs, particularly rodents. Many reports in literature have pointed out the severe limitation of current killed whole cells vaccines in terms of degree of protection and the wide range of side effects (5, 25). Subunit vaccines are the most attractive available option, in particular, the recombinant F1, V, and F1-V fusion, which have been extensively tested in the mouse system in terms of immunogenicity and protection (6, 11, 13, 26–28). Guinea pigs have also proved to be a suitable model system and have been used in protection studies using recombinant F1 and V produced

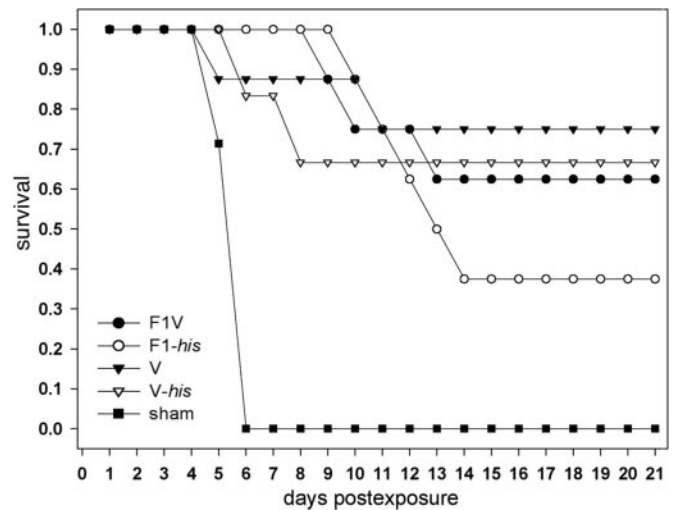

Fig. 6. Survival of vaccinated Hartley guinea pigs ($n = 8$ per group) to aerosolized *Y. pestis* (CO92). Animals were challenged with 61 ± 15 LD₅₀ (1 LD₅₀ = 21,000 colony-forming units).

in *E. coli* (3). Moreover, recently Williamson and colleagues (29) demonstrated the efficacy of the rF1 and rV antigens to elicit immune responses in healthy volunteers in a phase-I safety and immunogenicity trial.

In this work, we demonstrated the efficacy of plant-produced recombinant F1, V, and F1-V by using the guinea pig model and the feasibility of rapidly achieving high levels of expression by using a transient TMV-based system in plants. Antigens produced in plants have been proven to retain antigenicity and immunogenicity when tested in different animal systems and human volunteers (17, 30–33). Antigenic proteins are commonly produced with stably transformed plants, which have the great advantage of huge scalability. However, stable transgenic plants often show relatively low expression levels, typically $<100 \mu\text{g}\cdot\text{g}^{-1}$ of fresh leaf weight. TMV vectors were used for the expression of foreign proteins in plants and in different strategies for vaccine development, such as fusions of immunodominant epitopes to the coat protein to create chimeric TMV particles (34–36), or antigens expressed from additional ORFs driven by a viral subgenomic promoter (37, 38). In this study the *Yersinia* antigens were produced by using a TMV-derived system developed by Icon Genetics (22, 23), which produced outstanding expression levels ranging from $1 \text{ mg}\cdot\text{g}^{-1}$ of fresh leaf weight for F1-V to $2 \text{ mg}\cdot\text{g}^{-1}$ of fresh leaf weight for F1 and V. Although less than the $5 \text{ mg}\cdot\text{g}^{-1}$ of fresh leaf weight reported for GFP (22), this amount is still at least an order of magnitude greater than any antigen yet expressed in stably transformed plants. Our current production models indicate that a scaled-up magnICON system could be economically competitive with fermentation systems for these antigens (Barry Holtz, personal communication).

This particular system has a deletion of the TMV coat protein, thus limiting its ability to spread systemically throughout the plant. Without the coat protein the virus is still able to move from cell to cell but loses the ability for systemic infection, which allows a stringent containment of the virus. The host plant system we used is *N. benthamiana*, a nonfood and nonfeed crop. All constructs were efficiently expressed, and the encoded proteins accumulated when targeted to the different compartments, except for F1-V with the C-terminal His tag, which could not be expressed properly. Moreover, the cytosolic targeting proved to be the most efficient for all antigens, which is counterintuitive for F1, a normally secreted protein. This finding shows the inherent difficulty of predicting the expression of any

particular antigen and that empirical verification is the only way to proceed. Such empirical studies are greatly facilitated by the magnICON system, which allows a single antigen construct to be combined pairwise with various targeting elements in separate constructs. Indeed, F1 also showed high expression levels when targeted to the apoplast; however, the cleavage of the targeting presequences appeared incomplete, thus resulting in two bands corresponding to processed and unprocessed protein forms. Considering that the F1 protein sequence contains an N-linked glycosylation site (N-F-T) at position 62–64, an alternative explanation is that glycosylated and nonglycosylated forms of the protein accumulate (Fig. 2A).

The purified plant-derived antigens effectively protected guinea pigs against aerosol challenge with *Y. pestis* at an aerosol dose considered essentially 100% lethal to unvaccinated controls (61 ± 15 LD₅₀, or $\approx 1,281,000$ organisms). From the standpoint of survival, V, V-His, and F1-V provided similar protective efficacy in this pneumonic model of disease. Animals vaccinated with F1-His were apparently less well protected, although the serum anti-F1 IgG titers were similar to anti-V titers. This observation suggests that immunity to V antigen is a more important element of protection than immunity to F1 in the guinea pig model. Other published studies have used mice more frequently, and no other studies to our knowledge have assessed a direct comparison of protective efficacy for F1 and V antigens alone. When used in combination, the optimal molar ratio for protection of mice against s.c. challenge was 2:1 (F1/V) (39), suggesting that V is a more potent immunogen in mice. The observation that V antigen alone can protect effectively against aerosol challenge is comforting when one considers the existence of *Y. pestis* strains that do not express F1 antigen.

Interestingly, the time course of anti-V IgG production was most rapid for V, whereas V-His provoked substantial increases only after the first boost, and F1-V only after the second boost (Fig. 5). However, all three antigens produced similar anti-V titers after the second boost, which correlates with similar levels of survival upon challenge of these groups. It is interesting to speculate whether the presence of C-terminal His tag on the V-His antigen or the N-terminal F1 on the F1-V fusion might interfere with rapid immune responses to V.

In conclusion, we have demonstrated a rapid and robust plant-based expression system for highly effective vaccine immunogens of *Y. pestis*.

Materials and Methods

Construction of Expression Vectors. A synthetic gene was designed encoding a fusion of the *Y. pestis* F1 and V proteins (12), which was optimized for expression in dicotyledonous plants by using preferred codons and eliminating spurious mRNA processing signals (GenBank accession no. DQ229852). The gene was assembled by a commercial supplier, and the 1,456-bp purified NcoI–SacI fragment was ligated into the magnICON 3' module cloning vector pICH11599, resulting in plasmid pICH18330 (Fig. 1). The 449-bp NcoI–BspHI fragment, encoding for the F1 protein, was blunted at the BspHI site and subcloned into pICH11599 opened with NcoI–HindIII and blunted at the HindIII site, generating pICH18320. The 981-bp V gene was subcloned by blunting the KpnI site of the BspHI–KpnI fragment from the F1-V gene fusion and subcloned into the prepared NcoI–HindIII pICH11599 plasmid blunted at the HindIII site, resulting in plasmid pICH18574. To generate the His-tagged expression vectors a His tag adapter was first cloned in pICH11599 digested with SacI–PstI. The adapter was made with primers Hisad1 (5'-CCTCGAGCACCATCACCATCACCAT-TGACTGCA) and Hisad2 (5'-GTCAATGGTGTGATGGTGA-TGGTCTCGAGGAGCT). The resulting construct was pICH18342. A NcoI/XhoI fragment containing the F1 gene was subcloned into pICH18342 digested with NcoI/XhoI, resulting

in pICH18350 (F1-His). A NcoI/XhoI fragment containing the F1-V gene fusion was subcloned into pICH18342 digested with NcoI/XhoI, resulting in pICH18360 (F1-V-His). A BspHI/XhoI fragment was subcloned into pICH18342 digested with NcoI/XhoI, resulting in pICH18560 (V-His).

Agro Infiltration and Plant Infection. Two hundred microliters of overnight *Agrobacterium* cultures, OD₆₀₀ ranging from 1.6 to 2.5, was sedimented at $6,000 \times g$ for 3 min. The pellet was resuspended in 1 ml of a solution containing 10 mM Mes (pH 5.5) and 10 mM MgSO₄. Leaves of greenhouse-grown *N. benthamiana* plants were infiltrated by using a syringe without needle. Alternatively, for large-scale infiltration, all aerial parts of an entire plant were submerged into the *Agrobacterium* solution, and a vacuum of 0.5–1 bar was applied for 1–2 min and gently released.

Protein Extraction. *N. benthamiana* leaf material was harvested at 10 days postinfection. Leaves were frozen in liquid nitrogen and ground in a mortar. Extraction buffer was used at a ratio of 8 ml per g of prepared material. Extracts were clarified by centrifugation at $4,800 \times g$ for 30 min at 4°C. The supernatant was filtered sequentially through miracloth, 0.8- and 0.45- μ m filters, before chromatographic purification.

Purification of His-Tagged F1 and V Antigens. The C-terminal His-tagged F1 and V antigens were purified by using Ni-NTA agarose (Qiagen) at room temperature under gravity. The purification was performed under nondenaturing conditions, using lysis buffer Tween (50 mM NaH₂PO₄/300 mM NaCl/0.05% Tween 20, pH 8.0) as extraction buffer. Columns were washed with wash buffer Tween (50 mM NaH₂PO₄/300 mM NaCl/0.05% Tween 20, pH 6.3). The His-tagged proteins were eluted with elution buffer Tween (50 mM NaH₂PO₄/300 mM NaCl/0.05% Tween 20, pH 4.5). The proteins were collected as 2-ml fractions, which were analyzed by SDS/PAGE. Desalting and concentration of samples was performed by ultrafiltration in Macrosep 3K Omega centrifugal devices (Pall). The desalted samples were frozen in liquid nitrogen and lyophilized (Gamma 1-20, Martin Christ Gefriertrocknungsanlage, Osterode, Germany).

Anion Exchange Chromatography Purification of F1, V, and F1-V Antigens. The anion exchanger Q Sepharose Fast Flow (Amersham Pharmacia Biosciences) was used. For V and F1-V purification, 20 mM bis-Tris-HCl buffer (pH 6.5) was used to extract the recombinant proteins and equilibrate and wash the columns. The same buffer with increasing step gradient concentrations of sodium chloride (0.06, 0.12, 0.25, 0.5, and 1 M) was used as elution buffer. For the F1 antigen, 20 mM L-histidine (pH 5.6), 2 mM EDTA, and 0.1% Triton X-100 was used for protein extraction, equilibration, and washings of the columns, and the same buffer with increasing concentration of sodium chloride (0.06, 0.12, 0.25, 0.5, and 1 M) was used for elution. Fractions of 5 ml were collected. Concentration and buffer exchange of the fractions was achieved by ultrafiltration (Macrosep 10 K Omega, Pall) with two washes of 15 ml of water, and eluted fractions were pooled. Samples were concentrated 2- to 4-fold and reconstituted to the initial volume with water. This procedure was repeated four or five times for a complete buffer exchange. The desalted samples were frozen in liquid nitrogen and lyophilized.

SDS/PAGE and Western Blotting. For quantification, 100-mg samples of *N. benthamiana* leaves infiltrated with *Agrobacterium* and collected at 10 days postinfection were ground in 300 μ l of protein extraction buffer (50 mM sodium phosphate buffer, pH 7.0/5 mM 2-mercaptoethanol/10 mM EDTA/0.1% Triton X-100). Crude leaf extracts were fractionated on 10% or 12%

polyacrylamide gels by using the buffer system of Laemmli (40) followed by Coomassie staining (41). Proteins from SDS/PAGE (12% acrylamide) were electrophoretically transferred to nitrocellulose sheets as described by Towbin *et al.* (42). The membranes were blocked with 5% nonfat dry milk in PBS (DM/PBS) for 1 h at 23°C and probed with polyclonal rabbit sera anti-F1, anti-V, or anti-F1-V (kind gift of A. Friedlander, U.S. Army Medical Research Institute of Infectious Disease) diluted 1:3,000 in 1% DM/PBS and successively with goat anti-rabbit IgG-horseradish peroxidase conjugate (Sigma) diluted 1:8,000 in 1% DM/PBS. Bound antibody was detected with ECL reagents (Amersham Pharmacia).

ELISA. F1, V, and F1-V were also quantified by direct ELISA. Successive dilutions of total protein extracts from 1:50 to 1:1,000 in PBS (50 μ l per well) were used to bind 96-well polyvinylchloride microtiter plates for 2 h at 37°C. The plates were blocked with 5% DM/PBS (150 μ l per well) for 1 h at 37°C. After washing the wells three times with PBS with 0.05% Tween 20 (PBST), rabbit anti-F1, V, or F1-V polyclonal antibodies were diluted 1:3,000 in 1% DM/PBST, added to the plate (50 μ l per well), and incubated 2 h at 37°C. Subsequently, a goat anti-rabbit IgG-horseradish peroxidase conjugate (Sigma), 1:3,000 in 1% DM/PBST, was added and incubated for 1 h at 37°C. The plate was developed with Slow TMB substrate (Pierce) for 15 min at 23°C. The reaction was ended by addition of an equal volume of 0.5 M H₂SO₄, and absorbance was read at 450 nm. For a standard curve, bacteria-derived F1, V, and F1-V were diluted with PBS to concentrations ranging from 0.95 to 62.5 ng/ml and processed as above.

Animal Immunization, Serum Antibody Determination, and Challenge.

Groups of female Hartley guinea pigs ($n = 8$) (Covance Laboratories, Vienna, VA) weighing \approx 1.5 kg at initiation were vaccinated by s.c. injection with 25 μ g antigen per dose on days 0, 30, and 60. The antigens were purified plant-derived F1-V, F1-His, V, or V-His, in PBS buffer, adsorbed to 180 μ g alum adjuvant (Alhydrogel) (Superfos, Vedbaek, Denmark) adjuvant. The sham immunization group was injected with commixed PBS and Alhydrogel only. Serum samples were obtained before the first dose (preimmune) and 2 weeks after each vaccination. Four weeks after the second boost, animals were challenged by aerosol to *Y. pestis* (CO92) as described (13). The resulting challenge dose was calculated at 61 ± 15 LD₅₀ (1 LD₅₀ = 21,000 colony-forming units inhaled).

Serum IgG antibodies specific for F1 or V antigens were determined by ELISA, as described (12). Endpoint titers were determined as the dilution at which the ELISA OD value was \geq 3 SDs above the mean of the prevaccination levels for all groups combined. Statistical analysis involved Repeated Measures ANOVA between immunized groups with posthoc ANOVAs against the sham immunization group, with step-down Bonferroni correction for multiple comparisons (43). ANOVA stratified by time point with posthoc Dunnett's test against the sham immunization group was also used (44).

We thank Dr. A. Friedlander for the gift of the polyclonal rabbit sera anti-F1, anti-V, and anti-F1-V and the bacteria-derived F1, V, and F1-V recombinant proteins; Dr. R. Kandzia for help with plant-derived recombinant antigens purification; and B. Gonzales and N. Stahl for technical help with the ELISA analysis. These studies were supported by Department of Defense Grant DAMD 17-02-2-0015.

1. Perry, R. D. & Fetherston, J. D. (1997) *Clin. Microbiol. Rev.* **10**, 35–66.
2. Weir, E. (2005) *Can. Med. Assoc. J.* **172**, 1555.
3. Jones, S. M., Griffin, K. F., Hodgson, I. & Williamson, E. D. (2003) *Vaccine* **21**, 3912–3918.
4. Bramwell, V. W., Eyles, J. E. & Oya Alpar, H. (2005) *Adv. Drug Delivery Rev.* **57**, 1247–1265.
5. Meyer, K. F., Hightower, J. A. & McCrumb, F. R. (1974) *J. Infect. Dis.* **129**, Suppl., S41–S45.
6. Andrews, G., Heath, D., Anderson, G., Jr., Welkos, S. & Friedlander, A. (1996) *Infect. Immun.* **64**, 2180–2187.
7. Nakajima, R. & Brubaker, R. R. (1993) *Infect. Immun.* **61**, 23–31.
8. Nakajima, R., Motin, V. L. & Brubaker, R. R. (1995) *Infect. Immun.* **63**, 3021–3029.
9. Une, T. & Brubaker, R. R. (1984) *J. Immunol.* **133**, 2226–2230.
10. Leary, S. E., Williamson, E. D., Griffin, K. F., Russell, P., Eley, S. M. & Titball, R. W. (1995) *Infect. Immun.* **63**, 2854–2858.
11. Hill, J., Leary, S., Griffin, K., Williamson, E. & Titball, R. (1997) *Infect. Immun.* **65**, 4476–4482.
12. Heath, D. G., Anderson, J., George, W., Mauro, J. M., Welkos, S. L., Andrews, G. P., Adamovicz, J. & Friedlander, A. M. (1998) *Vaccine* **16**, 1131–1137.
13. Glynn, A., Roy, C. J., Powell, B. S., Adamovicz, J. J., Freytag, L. C. & Clements, J. D. (2005) *Infect. Immun.* **73**, 5256–5261.
14. Usha, R., Rohll, J. B., Spall, V. E., Shanks, M., Maule, A. J., Johnson, J. E. & Lomonosoff, G. P. (1993) *Virology* **197**, 366–374.
15. Sijmons, P. C., Dekker, B. M., Schrammeijer, B., Verwoerd, T. C., van den Elzen, P. J. & Hoekema, A. (1990) *Bio/Technology* **8**, 217–221.
16. Haq, T. A., Mason, H. S., Clements, J. D. & Arntzen, C. J. (1995) *Science* **268**, 714–716.
17. Mason, H. S., Haq, T. A., Clements, J. D. & Arntzen, C. J. (1998) *Vaccine* **16**, 1336–1343.
18. Tavladoraki, P., Benvenuto, E., Trinca, S., De Martinis, D., Cattaneo, A. & Galeffi, P. (1993) *Nature* **366**, 469–472.
19. Owen, M., Gandecha, A., Cockburn, B. & Whitelam, G. (1992) *Bio/Technology* **10**, 790–794.
20. Hiatt, A. (1990) *Nature* **344**, 469–470.
21. Ma, J. K. & Hein, M. B. (1995) *Plant Physiol.* **109**, 341–346.
22. Marillonnet, S., Giritch, A., Gils, M., Kandzia, R., Klimyuk, V. & Gleba, Y. (2004) *Proc. Natl. Acad. Sci. USA* **101**, 6852–6857.
23. Marillonnet, S., Thoringner, C., Kandzia, R., Klimyuk, V. & Gleba, Y. (2005) *Nat. Biotechnol.* **23**, 718–723.
24. Gleba, Y., Klimyuk, V. & Marillonnet, S. (2005) *Vaccine* **23**, 2042–2048.
25. Marshall, J. D., Jr., Bartelloni, P. J., Cavanaugh, D. C., Kadull, P. J. & Meyer, K. F. (1974) *J. Infect. Dis.* **129**, Suppl., S19–S25.
26. Glynn, A., Freytag, L. C. & Clements, J. D. (2005) *Vaccine* **23**, 1957–1965.
27. Eyles, J. E., Elvin, S. J., Westwood, A., LeButt, C. S., Alpar, H. O., Somavarapu, S. & Williamson, E. D. (2004) *Vaccine* **22**, 4365–4373.
28. Jones, S. M., Day, F., Stagg, A. J. & Williamson, E. D. (2000) *Vaccine* **19**, 358–366.
29. Williamson, E. D., Flick-Smith, H. C., LeButt, C., Rowland, C. A., Jones, S. M., Waters, E. L., Gwyther, R. J., Miller, J., Packer, P. J. & Irving, M. (2005) *Infect. Immun.* **73**, 3598–3608.
30. Mason, H. S., Ball, J. M., Shi, J. J., Jiang, X., Estes, M. K. & Arntzen, C. J. (1996) *Proc. Natl. Acad. Sci. USA* **93**, 5335–5340.
31. Tacket, C. O., Mason, H. S., Losonsky, G., Clements, J. D., Levine, M. M. & Arntzen, C. J. (1998) *Nat. Med.* **4**, 607–609.
32. Tacket, C. O., Mason, H. S., Losonsky, G., Estes, M. K., Levine, M. M. & Arntzen, C. J. (2000) *J. Infect. Dis.* **182**, 302–305.
33. Thanavala, Y., Mahoney, M., Pal, S., Scott, A., Richter, L., Natarajan, N., Goodwin, P., Arntzen, C. J. & Mason, H. S. (2005) *Proc. Natl. Acad. Sci. USA* **102**, 3378–3382.
34. Wu, L., Jiang, L., Zhou, Z., Fan, J., Zhang, Q., Zhu, H., Han, Q. & Xu, Z. (2003) *Vaccine* **21**, 4390–4398.
35. Yusibov, V., Hooper, D. C., Spitsin, S. V., Fleysch, N., Kean, R. B., Mikheeva, T., Deka, D., Karasev, A., Cox, S., Randall, J. & Koprowski, H. (2002) *Vaccine* **20**, 3155–3164.
36. Turpen, T. H., Reinl, S. J., Charoenvit, Y., Hoffman, S. L., Fallarme, V. & Grill, L. K. (1995) *Bio/Technology* **13**, 53–57.
37. Karasev, A. V., Foulke, S., Wellens, C., Rich, A., Shon, K. J., Zwierzynski, I., Hone, D., Koprowski, H. & Reitz, M. (2005) *Vaccine* **23**, 1875–1880.
38. Wagner, B., Hufnagl, K., Radauer, C., Wagner, S., Baier, K., Scheiner, O., Wiedermann, U. & Breiteneder, H. (2004) *J. Immunol. Methods* **287**, 203–215.
39. Williamson, E. D., Vesey, P. M., Gillhespy, K. J., Eley, S. M., Green, M. & Titball, R. W. (1999) *Clin. Exp. Immunol.* **116**, 107–114.
40. Laemmli, U. K. (1970) *Nature* **227**, 680–685.
41. Sambrook, J., Fritsch, E. F. & Maniatis, T. (1989) *Molecular Cloning: A Laboratory Manual* (Cold Spring Harbor Lab. Press, Plainview, NY).
42. Towbin, H., Staehelin, T. & Gordon, J. (1979) *Proc. Natl. Acad. Sci. USA* **76**, 4350–4354.
43. Holm, S. (1979) *Scand. J. Stat.* **6**, 65–70.
44. Zar, J. (1984) *Biostatistical Analysis* (Prentice-Hall, Englewood Cliffs, NJ).